

STRATA PLAN OF LOT 1 SECTION 22
 BLOCK 5 NORTH RANGE 1 WEST
 N.W.D. PLAN BCP25580
 B.C.G.S. 92G.027
 CITY OF SURREY
 SCALE 1:750

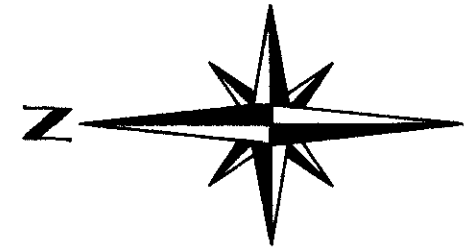

- LEGEND:
- SL Denotes Strata Lot
 - PT Denotes Part
 - T Denotes Total
 - m2 Denotes Square Metres
 - LCP Denotes Limited Common Property
 - D-1 Denotes Deck, LCP of Strata Lot 1 (Typical)
 - Denotes Control Monument found
 - Denotes Standard Iron Post Found
 - ⊙ Denotes Common Property

Grid Bearings are derived from observations between Control Monuments 5198 & 79H0019
 CIVIC ADDRESS: 10468
 157th ST. SURREY B.C.



SEC. 22
 REM 37
 REF. PLAN 64371
 TRANS CANADA HIGHWAY
 REF. PLAN LMP30421

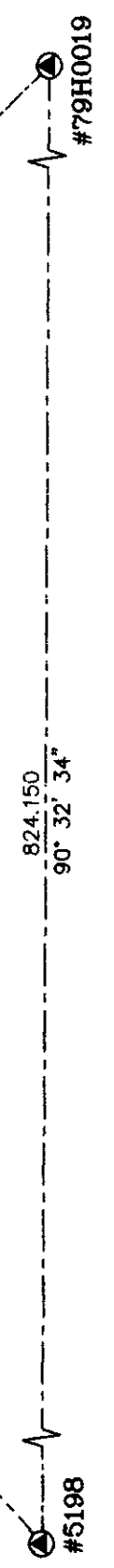
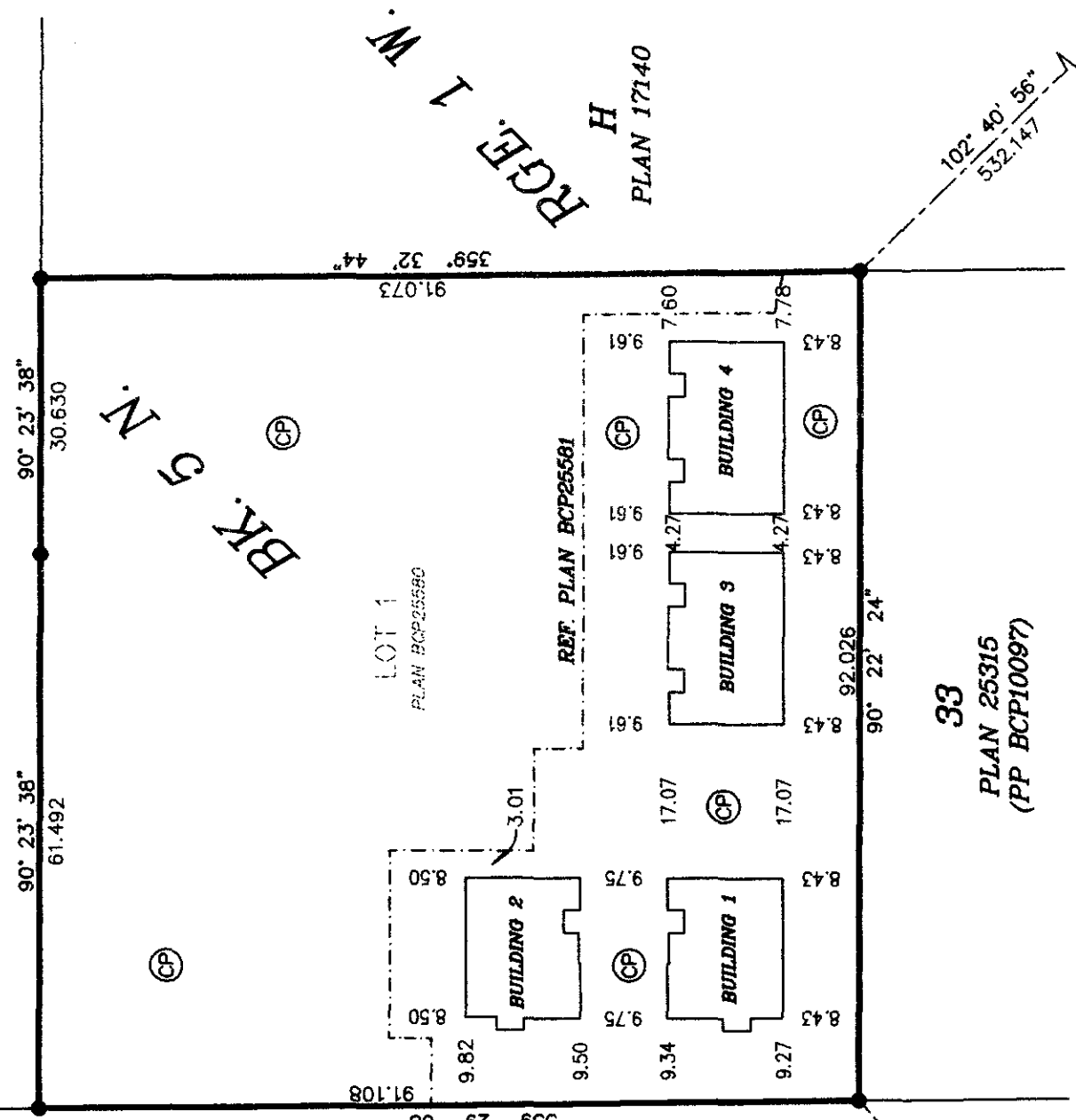

Integrated Survey Area No. 1
City of Surrey
 This plan shows ground level measured distances, prior to computation of U.T.M. coordinates multiply by combined factor of 0.9995950 NAD83 (CSRS)
 Underwater Land Surveying
 B.C. Land Surveyors
 #104-5830 176A Street
 Cloverdale B.C.
 FILE: JS0605_F1

I, John P. Underwater, a British Columbia Land Surveyor, certify that the buildings shown on this strata plan are within the external boundaries of the land that is the subject of the strata plan. Dated this 9th day of January, 2006.
 B.C.L.S.
 This Plan Lies Within The
 Greater Vancouver Regional District

I, John P. Underwater, a British Columbia Land Surveyor, of Cloverdale in British Columbia, certify that I was present at and personally supervised the survey represented by this plan, and that the survey and plan are correct. The field survey was completed on the 3rd day of January, 2007. The plan was completed and checked, and the checklist filed under #59369, on the 9th day of January, 2007.

SHEET 1 OF 7 SHEETS
 STRATA PL. BCS 2371
 Deposited in the Land Title Office at New Westminster B.C. on This 1st Day of June, 2007.
 I. mac Donald
 Registrar
 Ref. No. BB 266352
BB 266365

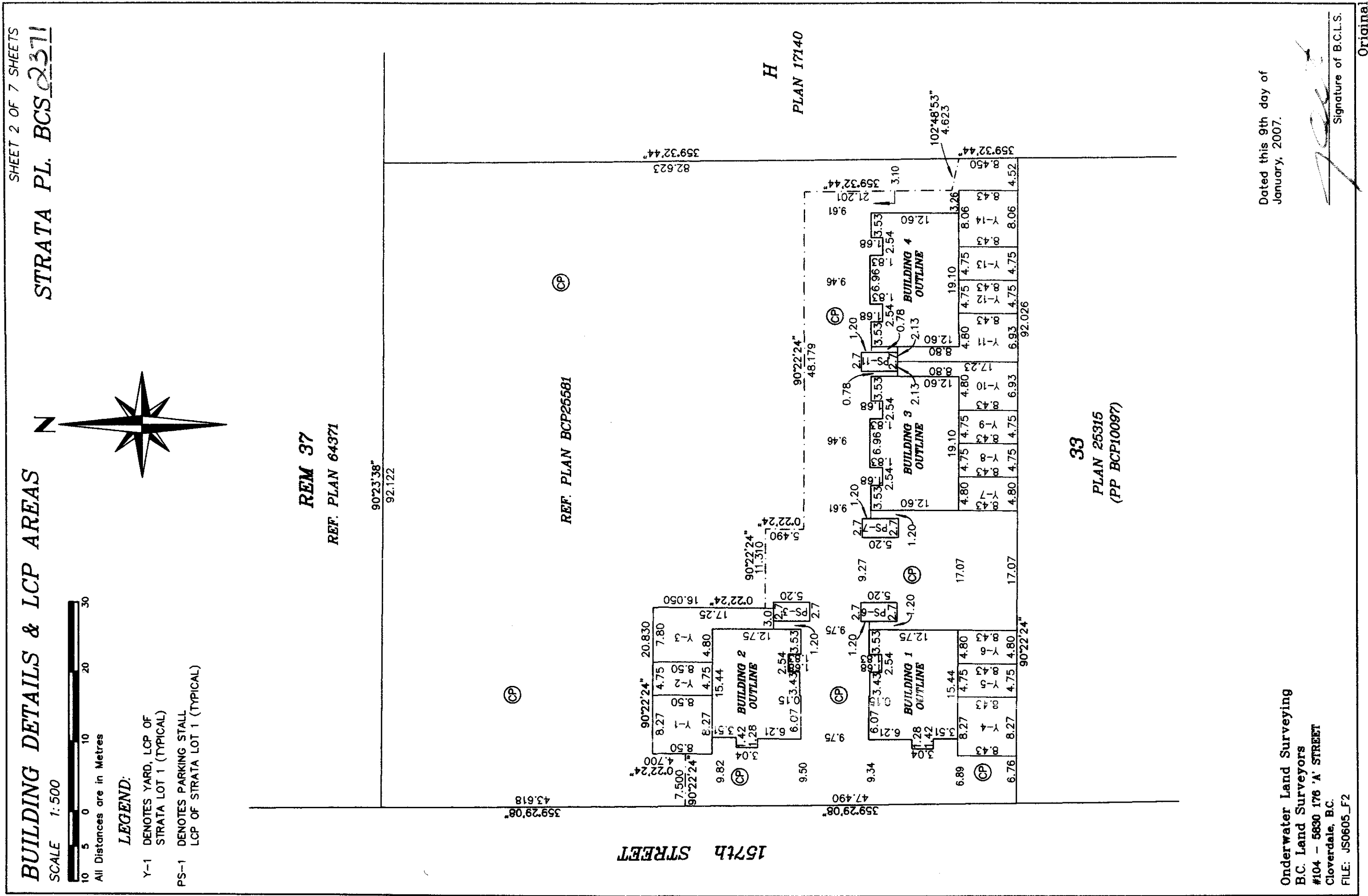

Underwater Land Surveying
 B.C. Land Surveyors
 #104 - 5830 176 'A' STREET
 Cloverdale, B.C.
 FILE: JS0605_F2

SHEET 3 OF 7 SHEETS

STRATA PL. BCS 2371

OWNERS:
GUILDFORD BROOK ESTATES INC.
(INC. NO. 0724323)
(sign and print name clearly)

[Signature]
AUTHORIZED SIGNATORY

AUTHORIZED SIGNATORY

[Signature]
WITNESS AS TO SIGNATURES

7525 King George Hwy.
ADDRESS OF WITNESS

Lawyer
OCCUPATION OF WITNESS

MORTGAGEE:
WESTMINSTER SAVINGS CREDIT UNION
(sign and print name clearly)

[Signature]
AUTHORIZED SIGNATORY

AUTHORIZED SIGNATORY

[Signature]
WITNESS AS TO SIGNATURES

4000 Bayview Dr, New Westminster
ADDRESS OF WITNESS

clerk
OCCUPATION OF WITNESS

FORM S
NEW DEVELOPMENT CERTIFICATE

I, John P. Underwater, a British Columbia Land Surveyor, certify that the buildings included in this strata plan have not as of the 9th day of January, 2007 been previously occupied.

[Signature]
B.C.L.S.

The City of Vancouver, British Columbia, by its holder of Certificate No. 16074, BA416076 and BA413081, consent to the filing of this strata plan.

[Signature]
MAYOR LYNNE L. WATTS

[Signature]
CLERK MARGARET JONES

Underwater Land Surveying
B.C. Land Surveyors
#104-5680 176A Street
Cloverdale B.C.

FILE: JS0605_F3

Dated this 9th day of
January, 2007.

[Signature]
Signature of B.C.L.S. Original

FLOOR PLANS BUILDING 2

SHEET 4 OF 7 SHEETS STRATA PL. BCS 2371

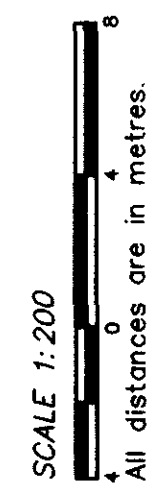

LEGEND:
D-1 Denotes Deck LCP of
Strata Lot 1 (Typical)

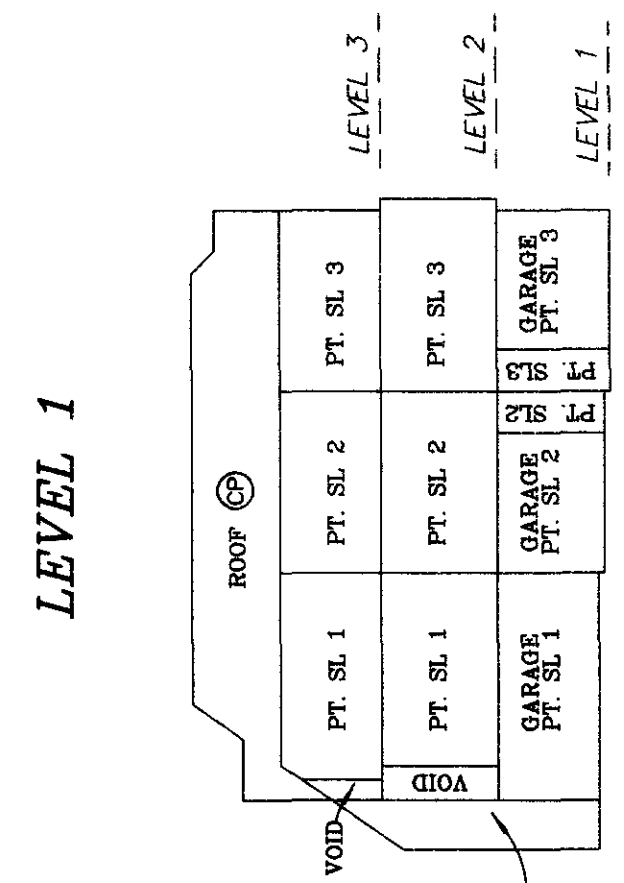
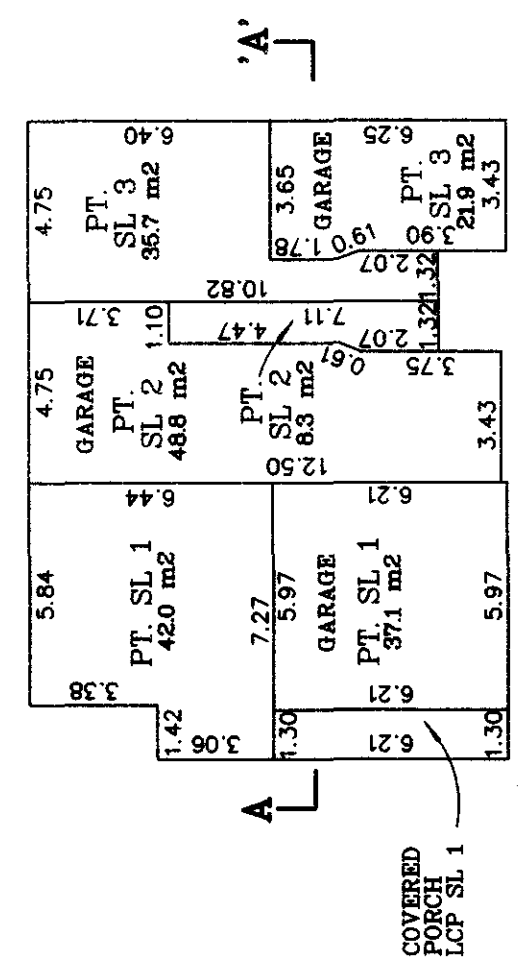
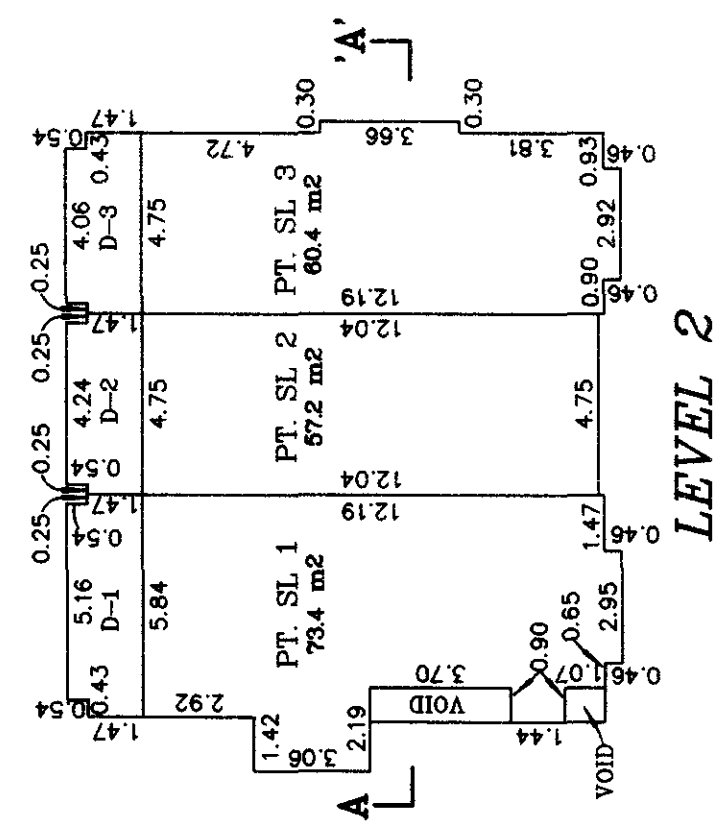
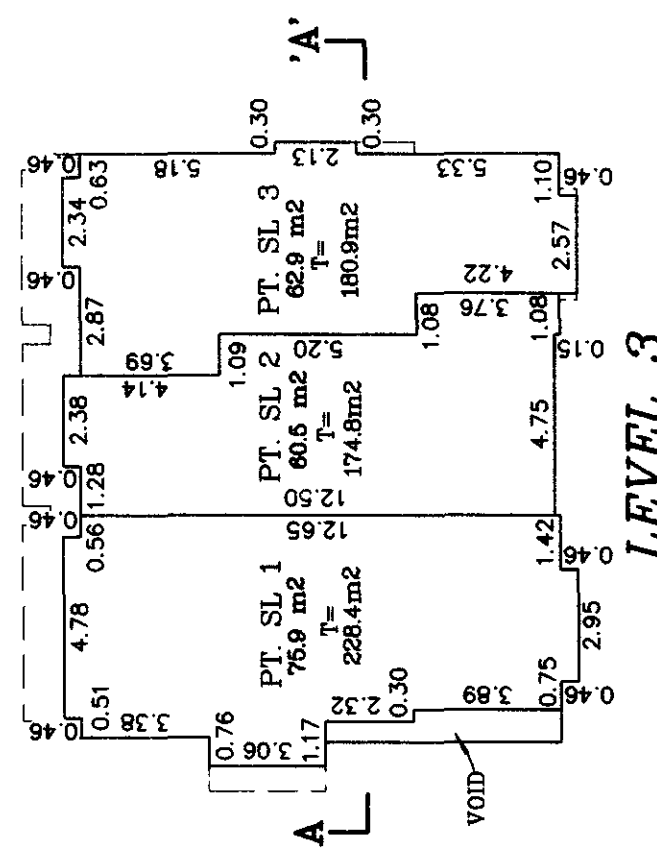
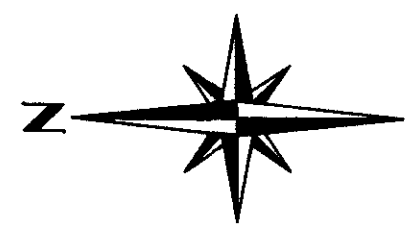

Underwater Land Surveying
B.C. Land Surveyors
#104-5890 176A Street
Cloverdale B.C.
FILE: JS0605_F4

Dated this 9th day of
January, 2007

Signature of B.C.L.S.

FLOOR PLANS BUILDING 1

SHEET 5 OF 7 SHEETS
STRATA PL. BCS 2371

SCALE 1:200



All distances are in metres.

LEGEND:

D-1 Denotes Deck LCP of
Strata Lot 1 (Typical)

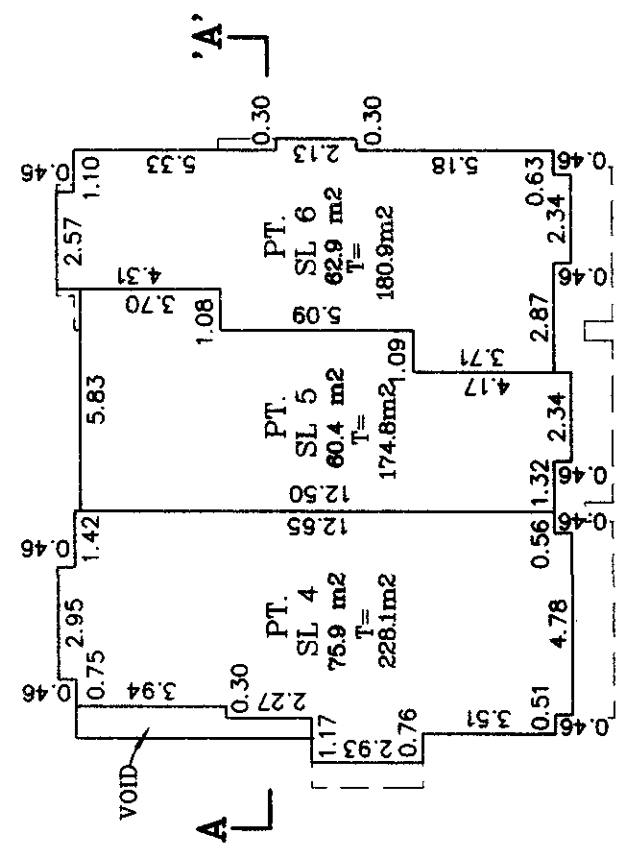
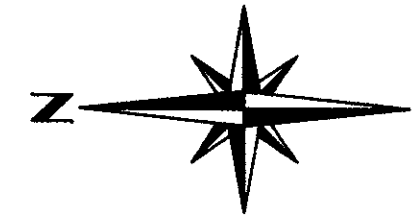

LEVEL 3

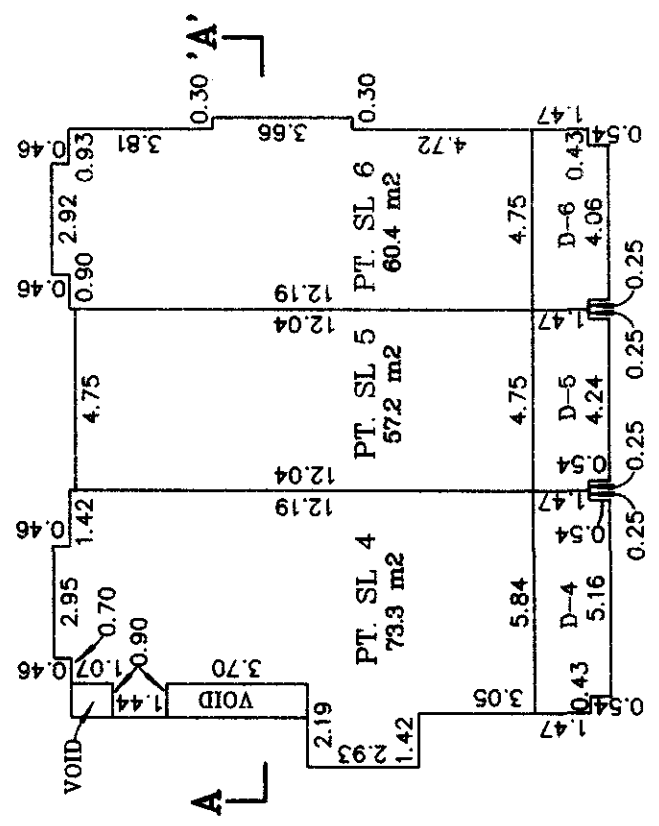

LEVEL 2

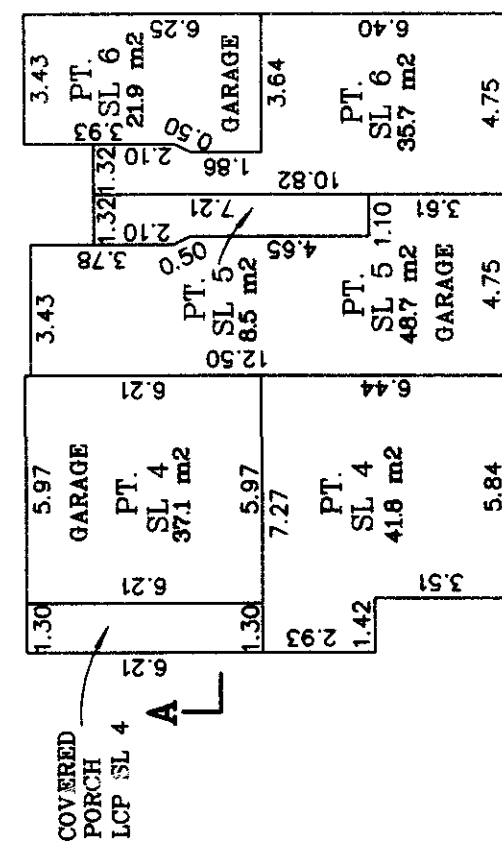

LEVEL 1

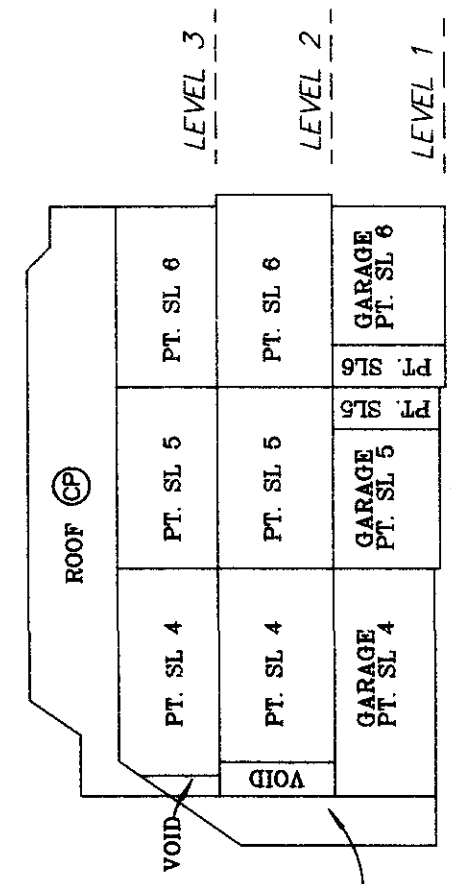

SECTION A - A'

Dated this 9th day of
January, 2007

Signature of B.C.L.S.
[Signature]

FILE: JS0605_5

Underwater Land Surveying
B.C. Land Surveyors
#104-5830 176A Street
Cloverdale BC.

Original

FLOOR PLANS
BUILDING 3
STRATA PL. BCS 2371
 SHEET 6 OF 7 SHEETS

SCALE 1:200

All distances are in metres.

LEGEND:
 D-1 Denotes Deck LCP of Strata Lot 1 (Typical)

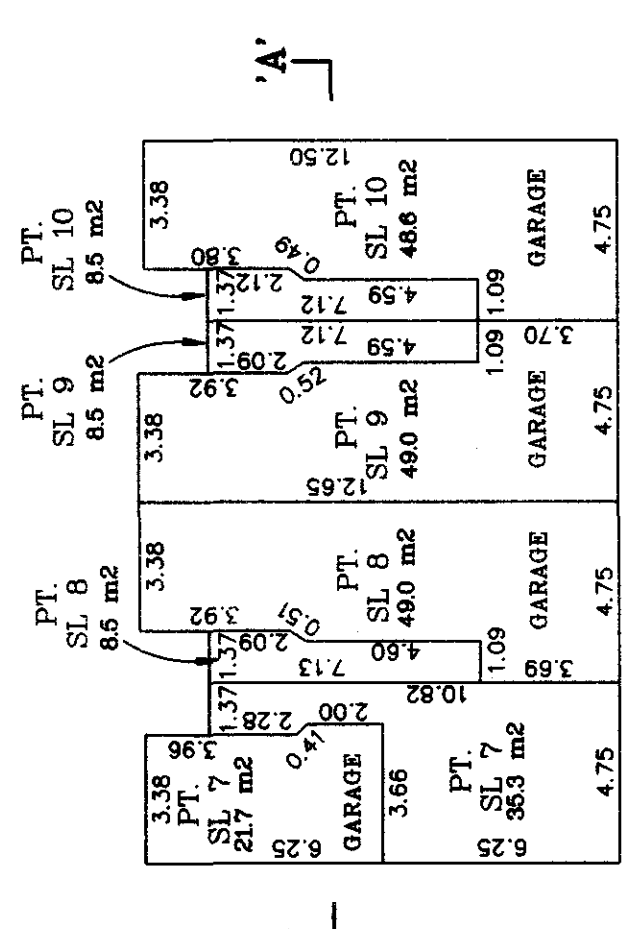
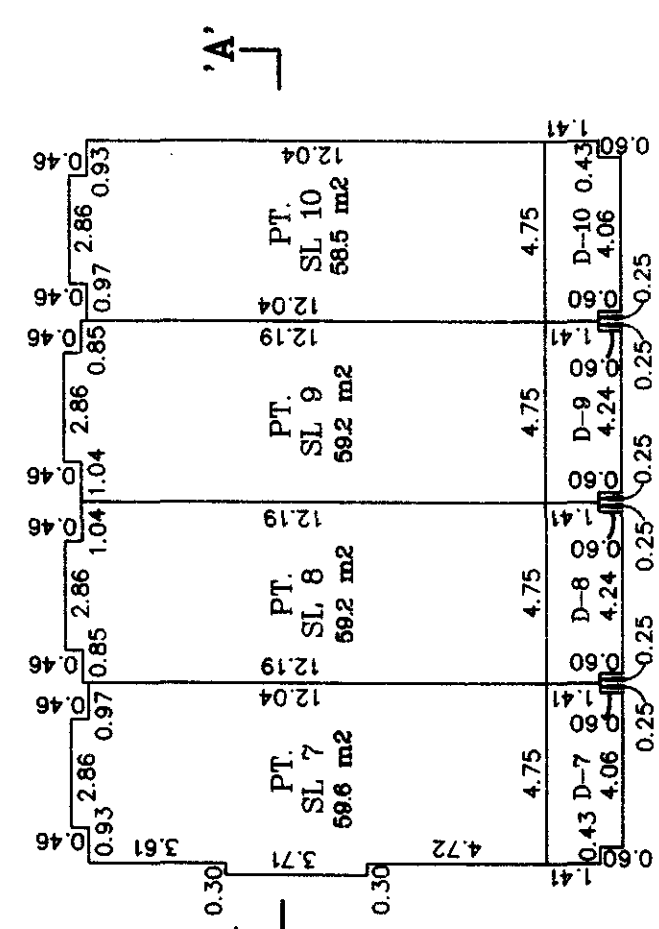
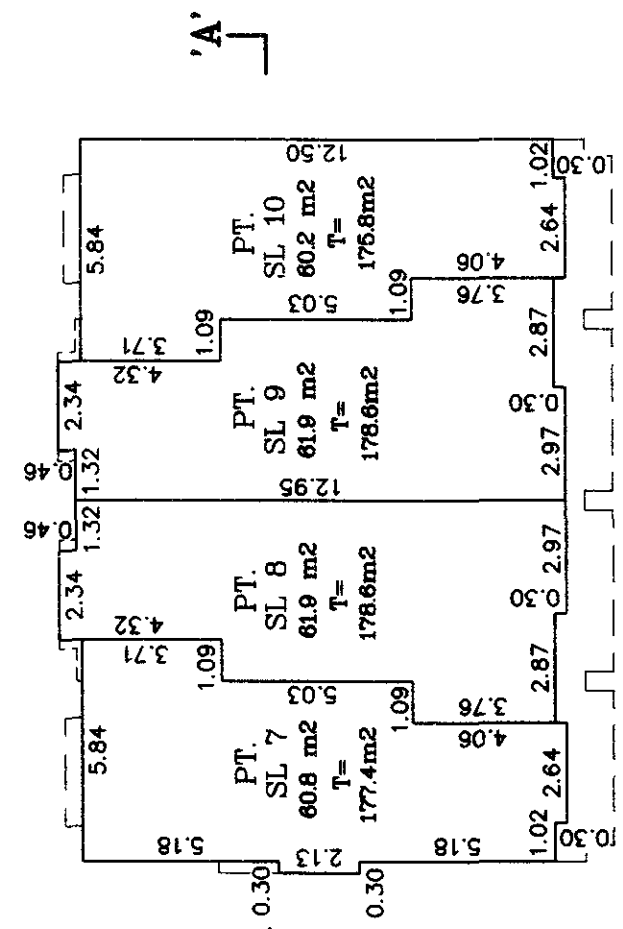
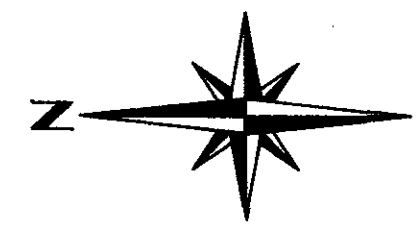

SECTION A - A'

ROOF (CP)			
PT. SL 7	PT. SL 8	PT. SL 9	PT. SL 10
PT. SL 7	PT. SL 8	PT. SL 9	PT. SL 10
GARAGE PT. SL 7	GARAGE PT. SL 8	GARAGE PT. SL 9	GARAGE PT. SL 10

Underwater Land Surveying
 B.C. Land Surveyors
 #104-5830 176A Street
 Cloverdale BC.
 FILE: JS0605_F6

Dated this 9th day of
 January, 2007.

Signature of B.C.L.S.

Original

FLOOR PLANS BUILDING 4

STRATA PL. BCS 2371

SHEET 7 OF 7 SHEETS

SCALE 1:200



All distances are in metres.

LEGEND:

D-1 Denotes Deck LCP of Strata Lot 1 (Typical)

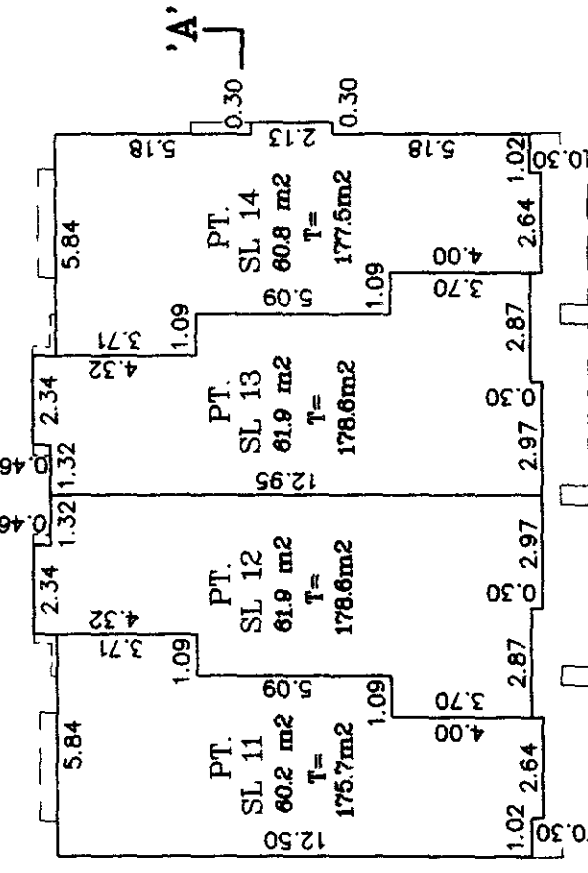
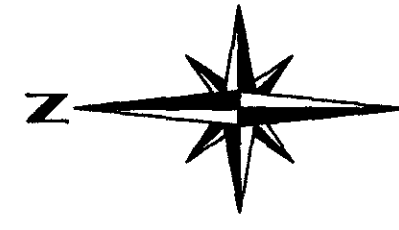

LEVEL 3

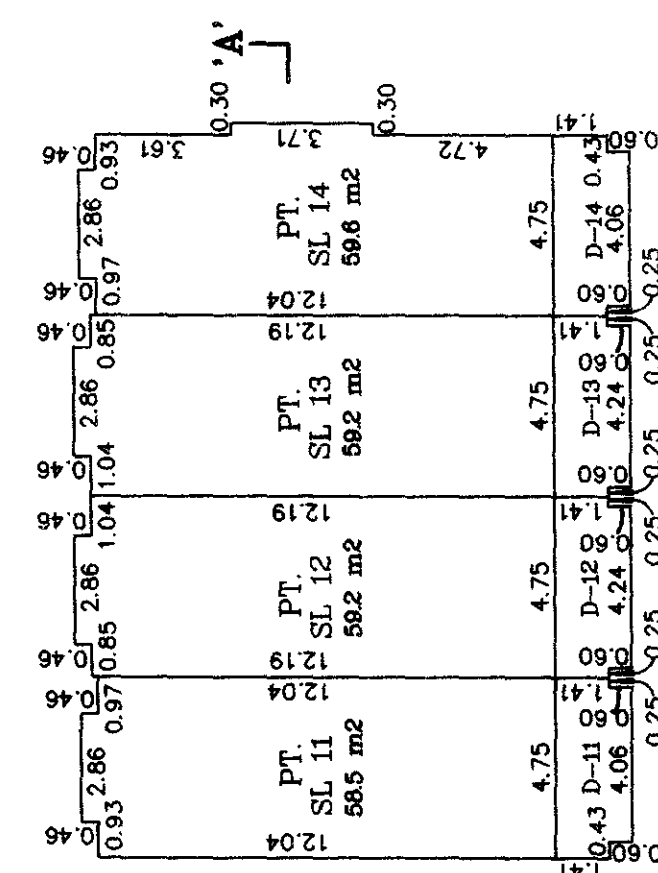

LEVEL 2

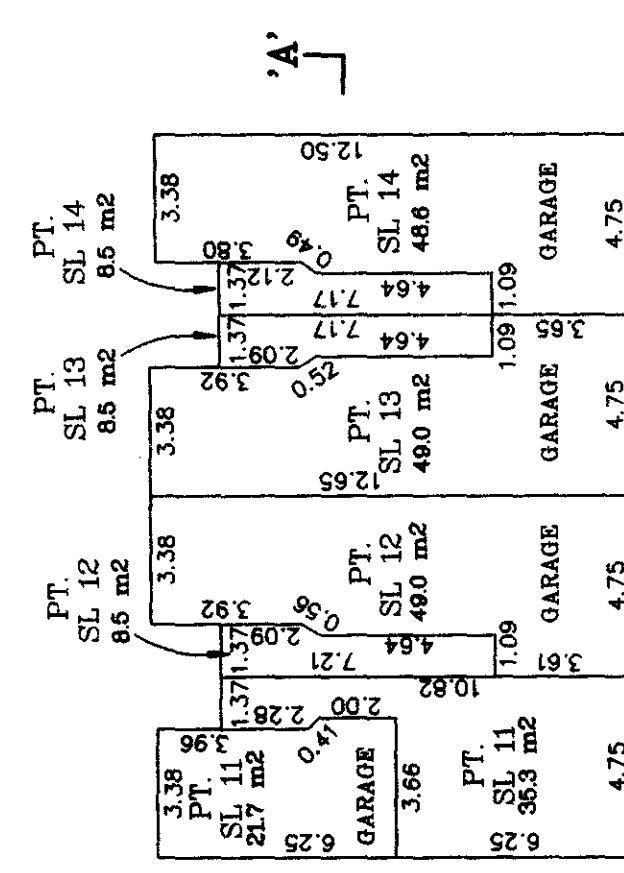

LEVEL 1

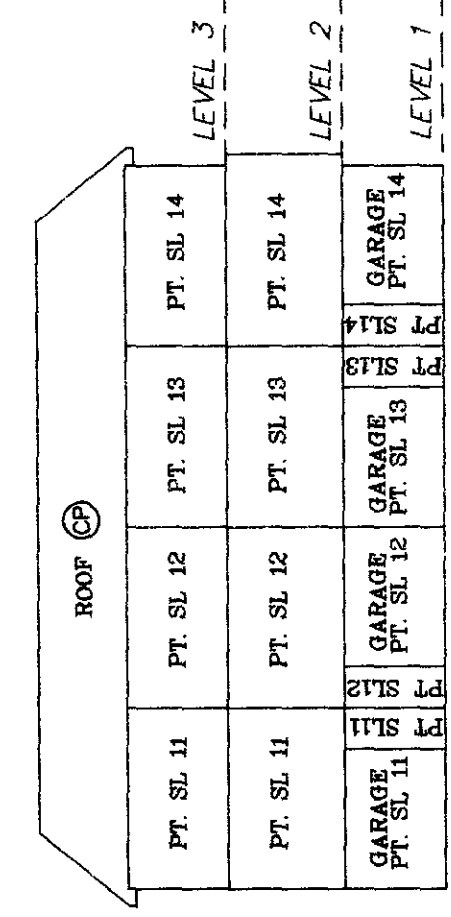

SECTION A - A'

Underwater Land Surveying
B.C. Land Surveyors
#104-5630 176A Street
Cloverdale B.C.

FILE: JS0605_F7

Dated this 9th day of
January, 2007.

[Signature]
Signature of B.C.L.S.

Original